

Kartell

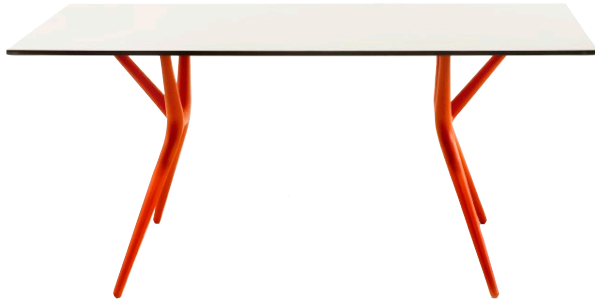

Spoon Table Antonio Citterio con Toan Nguyen

Technical sheet







Spoon Table is a folding light office table characterised by its extreme lightness and practicality. The structural surface is made of honeycomb aluminium and is only 15 mm thick. The finish is white laminate whereas the methacrylate edges are coloured on the bottom so that the transparency creates a sense of depth.

The thermoplastic legs are a guarantee of resistance and elasticity. The knee mechanism closing was developed for easy folding of the top and makes the Spoon Table perfect for living in small spaces and easy carrying. The leg-locking system requires no tools and works using only a slider eyelet.

The Spoon Table comes in three sizes of top and with legs and matching edges in three colours.

4506 / 4507 / 4508

	Top	Leg
02/orange		
03/white		
09/black		

Material

Tabletop: honeycomb aluminium and melamine laminate

Leg: batch-dyed modified polypropylene

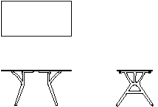
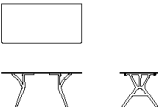
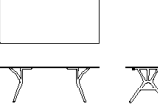
		width	height	depth	weight kg.
4506		140	72	70	16,500
4507		160	72	80	18,500
4508		200	72	90	20,000
packaging		quantity	weight kg.	volume m ³	
4506		1	24,500	0,180	
4507		1	26,500	0,230	
4508		1	28,000	0,320	

Sample Order Kit Layout 1

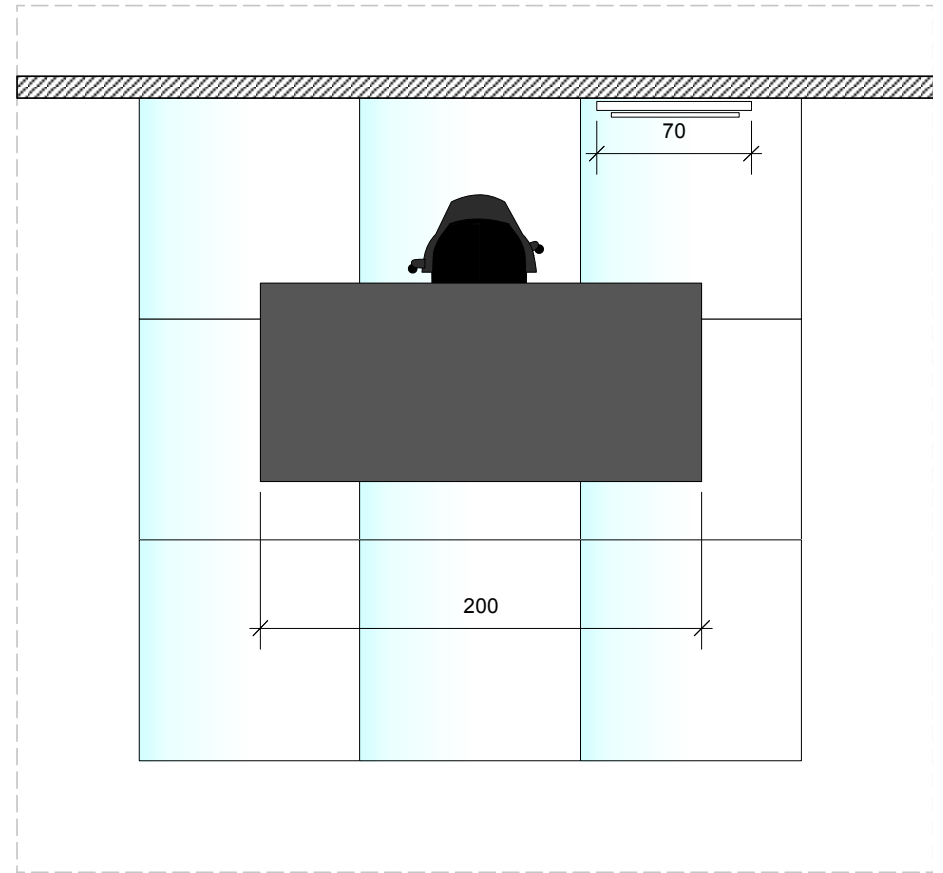
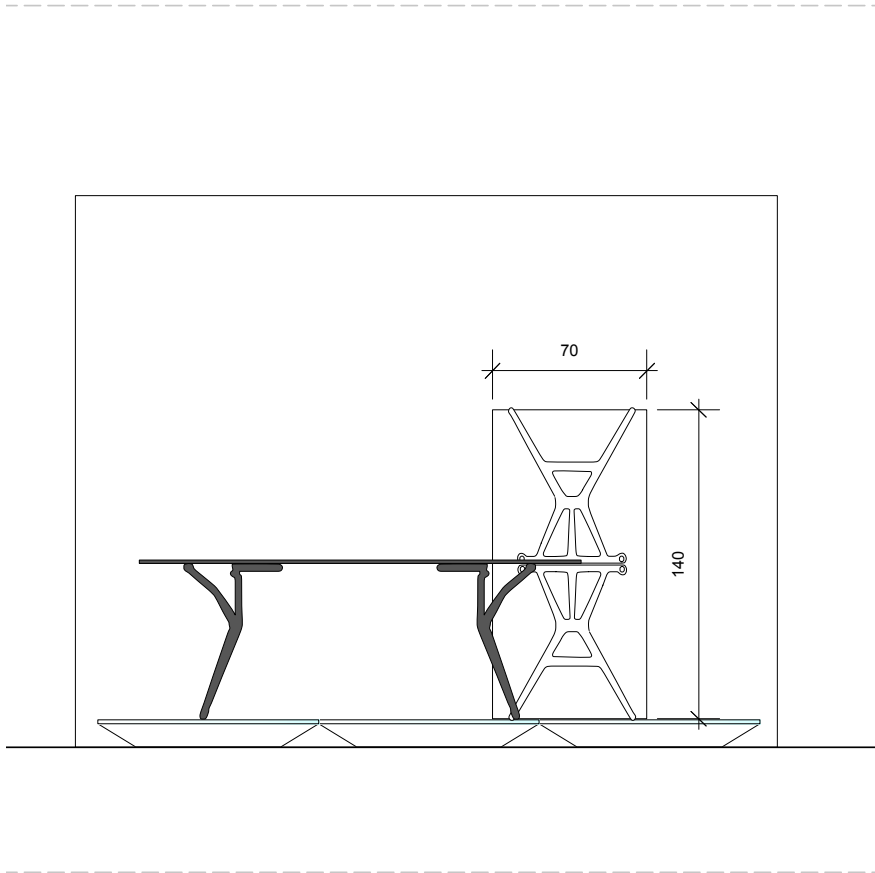

Sample Order Kit Layout 1

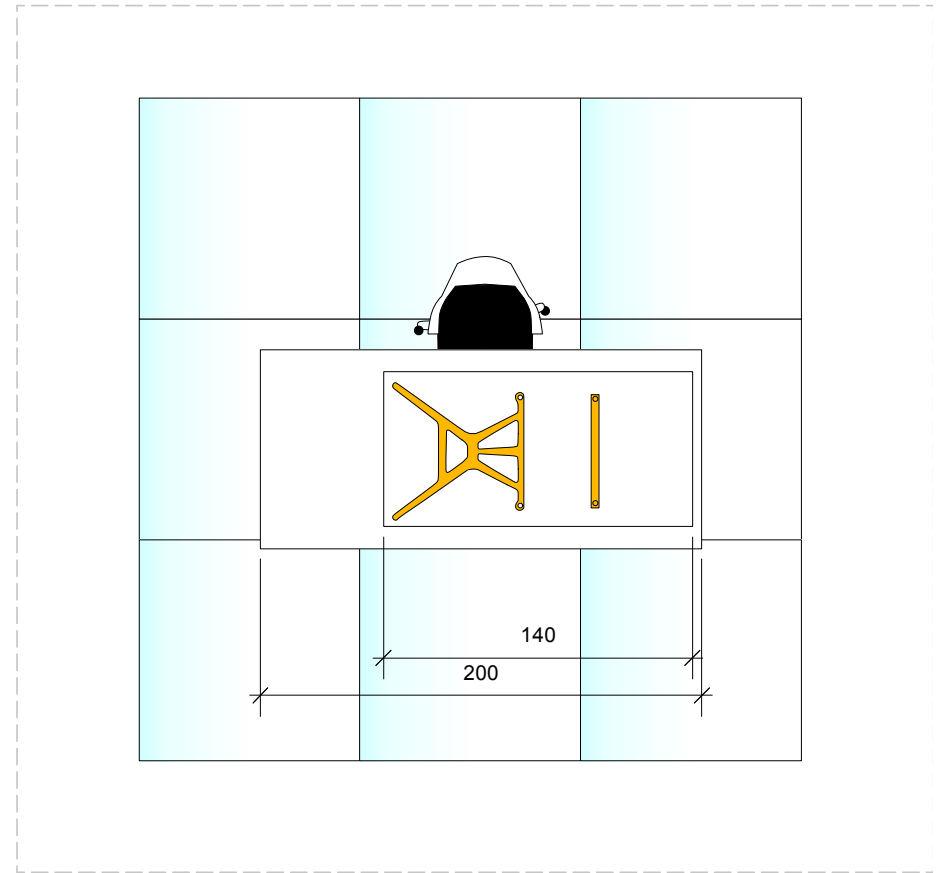
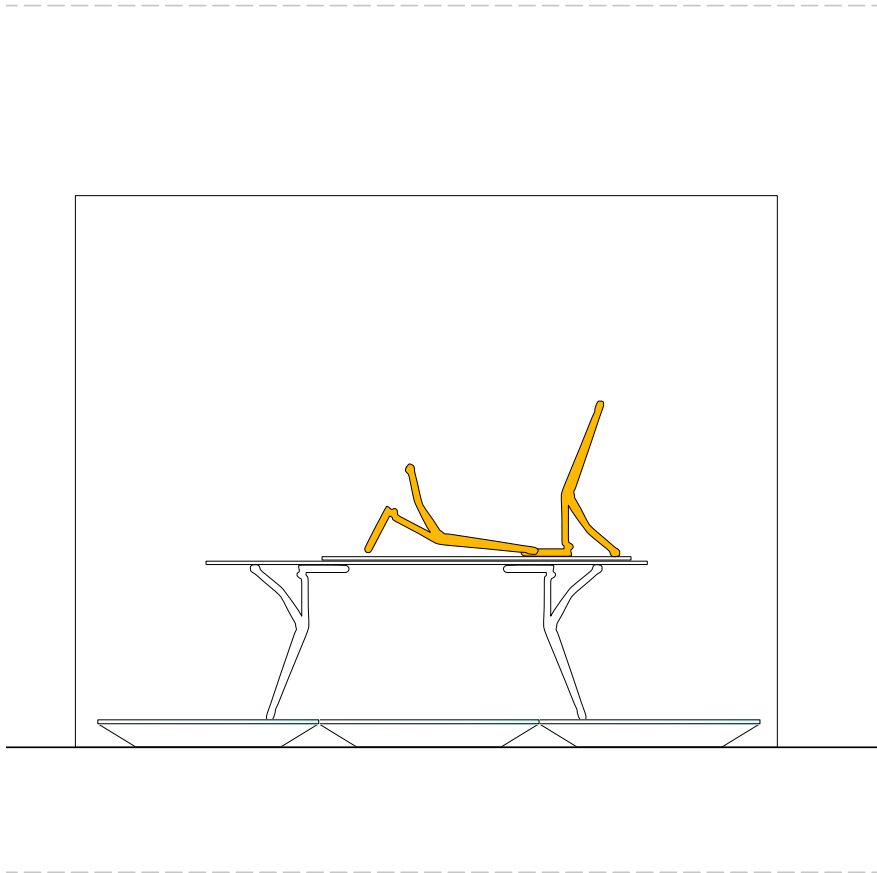



Layout Podium 1

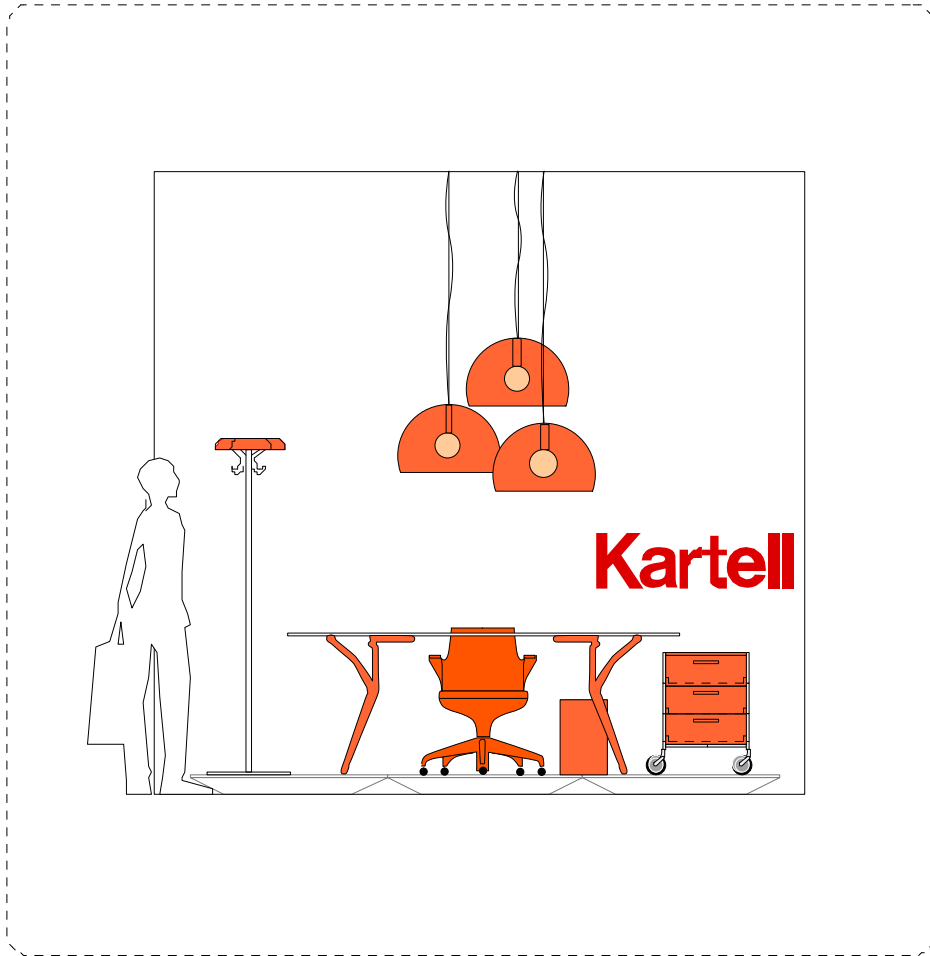

Front shop window

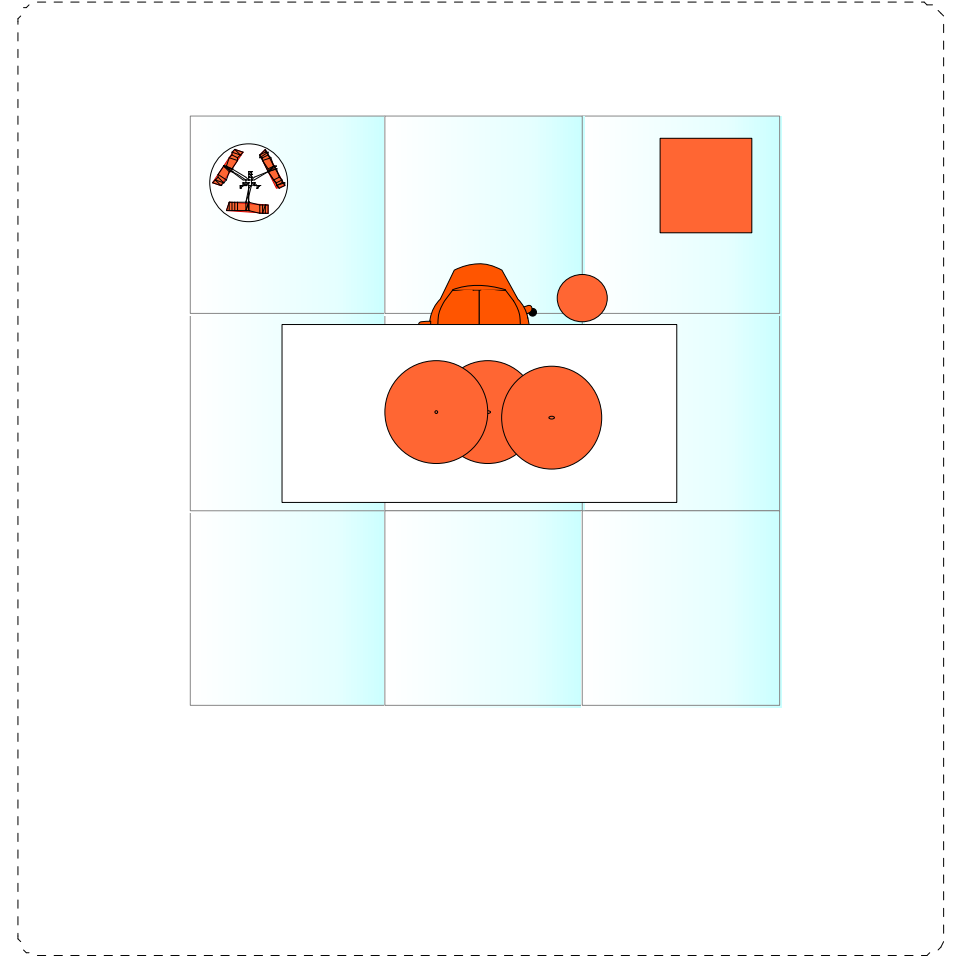

Layout Podium 2

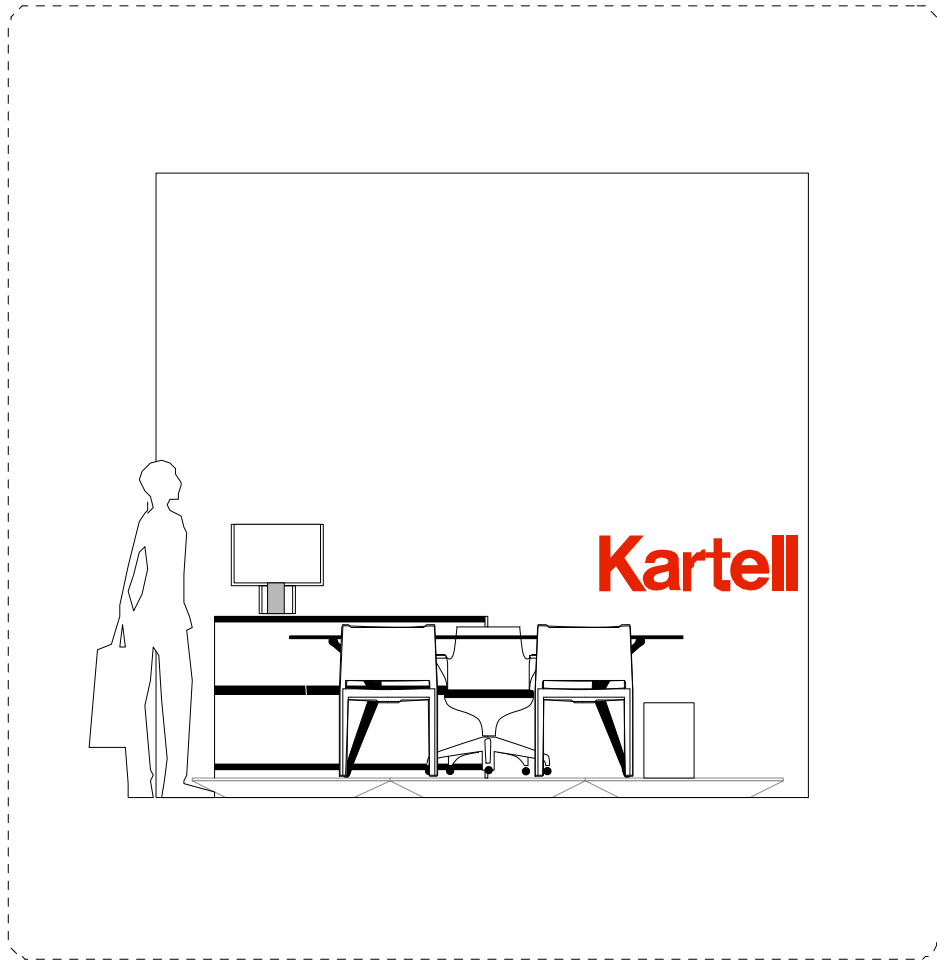

Front shop window

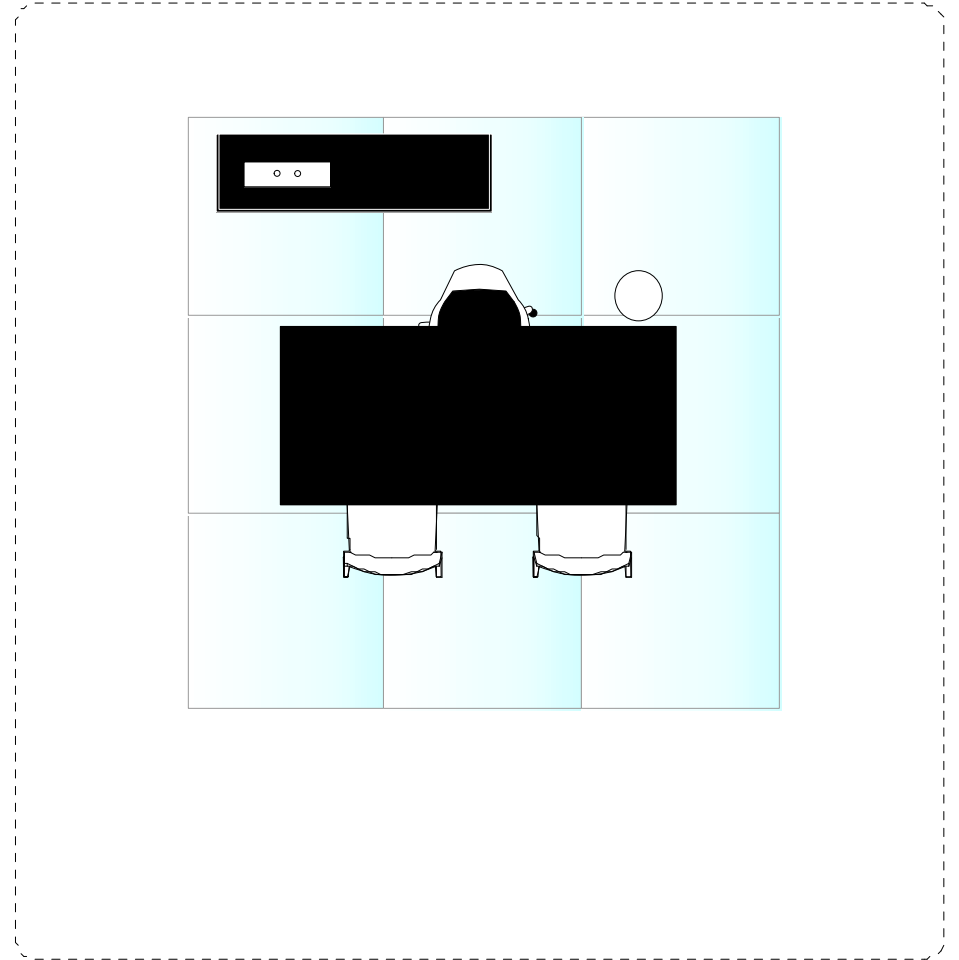

Layout Podium 3

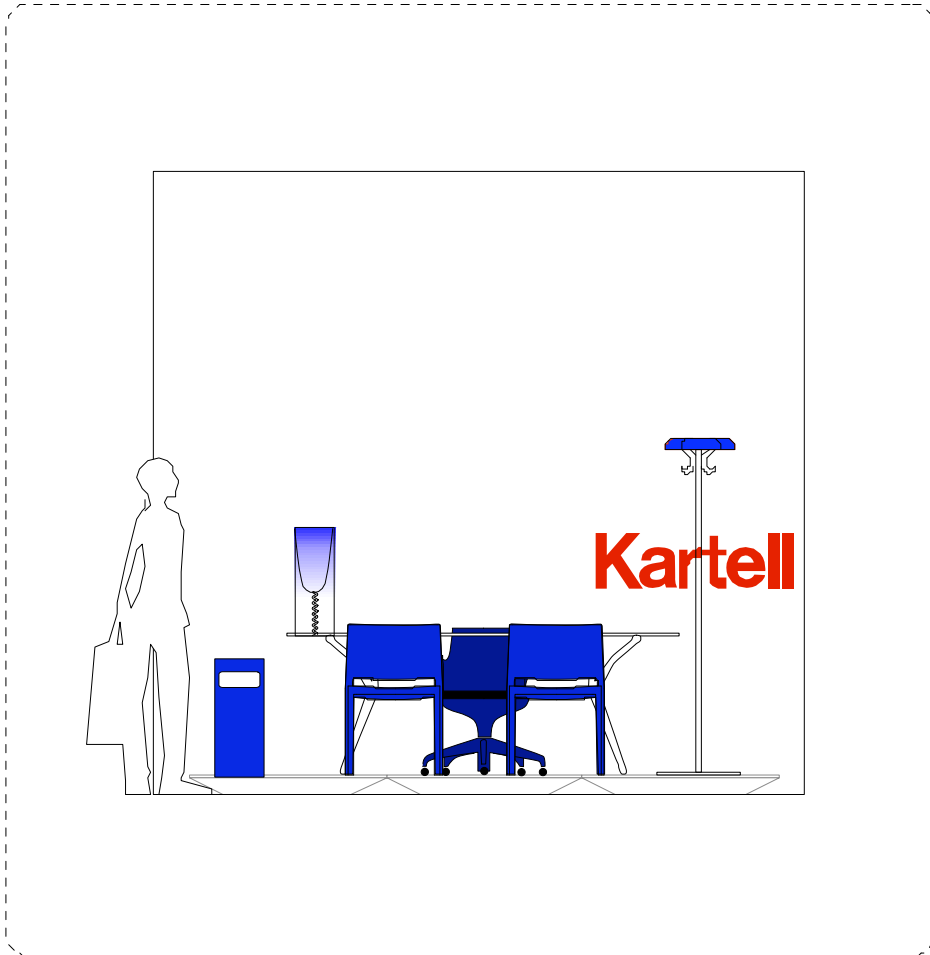

Front shop window

